

Model Code:
ESAC50RC

Product:
**5.0kW Reverse Cycle
Split Air-Conditioner**

Esatto

Features:

4 Fan Speeds
Sleep function
Turbo function
Self clean function
ECO function
Timer function
Fresh function

Programs:

5 program modes:
→ Auto
→ Cool
→ Heat
→ Dry
→ Fan

Indoor Product Dimensions:

Packaged (w, d, h mm)
→ 1155 × 415 × 315mm
Physical (w, d, h mm)
→ 1080 × 226 × 336mm
Weight (Net/Gross)
→ 13.9kg/17.7kg

Outdoor Product Dimensions:

Packaged (w, d, h mm)
→ 965 × 395 × 765mm
Physical (w, d, h mm)
→ 845 × 363 × 702mm
Weight (Net/Gross)
→ 43.5kg/46.8kg

Capacity:

Cooling 5.0kW
Heating 6.0kW

Noise Level:

Indoors:
→ 38–48 dB(a)
Outdoors:
→ 60 dB(a)

Energy Efficiency:

Cooling Energy Rating (MEPS):
→ 3.5 stars
Heating Energy Rating (MEPS):
→ 3.5 stars

Requirements:

Rated Voltage:
220-240V, 50Hz, 1Ph
Refrigerant:
R32/1.45Kg

Accessories:

Remote control

Warranty:

24 Months



↑ Product

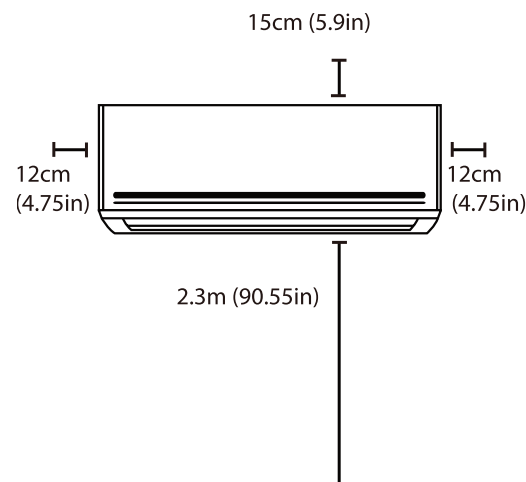

↑ Installation

