

Model Code/s:
EE62T

Product:
**60cm
Ceramic Cooktop**

Document:
User Manual

Esatto

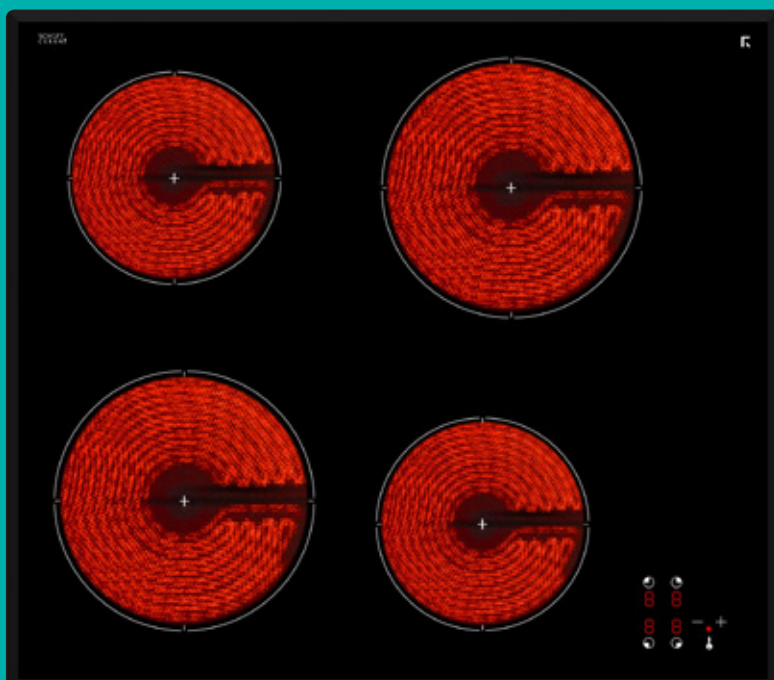

Dear Customer,

Congratulations on purchasing your new ceramic cooktop. The *Esatto* brand is proudly distributed within Australia by Residentia Group Pty Ltd.

Please refer to the warranty card at the rear of this manual for information regarding your product's parts and labour warranty, or visit us online at www.residentiagroup.com.au.

At Residentia Group, we are customer obsessed and our Support Team are there to ensure you get the most out of your appliance. Should you want to learn more about your cooktop such as the various features or importantly taking care of the appliance, our Support Team are here to help.

You can use our online Support Centre at anytime by visiting <http://support.residentiagroup.com.au>, or you can contact us via phone by dialling: 1300 11 HELP (4357).

It is important that you read through the following use and care manual thoroughly to familiarise yourself with the installation and operation requirements of your appliance to ensure optimum performance.

Again, thank you for choosing an *Esatto* appliance and we look forward to being of service to you.

Kind Regards,
The Residentia Team



User Manual:

Esatto

Contents:

	Page:
Safety instructions	4
Your Esatto Cooktop	6
Installation Instructions	7
Operating your Cooktop	11
Cleaning & Maintenance	13
Troubleshooting	14
Technical Data	15
Warranty Information	16
Notes	18



Safety Instructions

Your safety is of the utmost importance to. Please make sure that you read this instruction booklet before attempting to install or use the appliance. If you are unsure of any of the information contained in this booklet, please contact the Retailer where you purchased your unit from.

This cooktop must only be installed by a suitably qualified and licenced person and in accordance with the instructions provided. Incorrect installation may cause harm to persons, damage property and void the product's warranty.

IMPORTANT!

The electricity supply to the cooktop must be cut off before any adjustments or maintenance work is undertaken.

WARNING

When using this product, basic precautions should always be taken including the following:



This cooktop is designed for domestic household use and for the cooking and frying of domestic foodstuffs.

IMPORTANT!

The adjacent furniture and all materials used in the installation must be able to withstand a minimum temperature of 85°C above the ambient temperature of the room it is located in, whilst in use.



Certain types of vinyl or laminate kitchen cabinetry are particularly prone to heat damage or discolouration at temperatures above the guidelines given.



Any damage caused by the cooktop being installed in contravention of this temperature limit, will be the liability of the owner.



Your new cooktop is guaranteed against electrical or mechanical defects, subject to certain exclusions that are noted in the Warranty Terms and Conditions (at the rear of this user manual). The foregoing does not affect your statutory rights.



The use of this cooktop for any other purpose or in any other environment, without the express agreement of Residentia Group, will invalidate any warranty or liability claim.



You should not use this appliance to store items on or as a work surface.



No modifications to the appliance are permitted by Residentia Group.



You should not store or place flammable or highly flammable liquids/materials on top of or near the appliance. Items made from aluminium, plastic or plastic film should also be kept away from the appliance, as they may fuse to the surface.



Repairs may only be carried out by authorised service agents.



Your Esatto cooktop is not to be used by children or persons with reduced physical, sensory or mental capabilities, or lack of experience and knowledge, unless they have been given supervision or instruction.



Any film or stickers that are present on the cooktop when it is delivered should be removed before use.



Care should be used when utilising the cooktop, otherwise there is a risk of burns being caused.



You should not allow the electrical connection cables to come into contact with the cooktop surface when it is hot or any hot cookware.



If fat and oil overheats, then it can ignite extremely quickly. For this reason, when cooking with fat and oil the appliance should not be left unattended.



Make sure that all of the cooking zones are switched off after use.



Cleaning of the cooktop should be carried out on a regular basis, once the cooktop has cooled down.



Great care should be taken whilst using this appliance and when following the cleaning procedure.



You should not use a steam jet or any other high pressure cleaning equipment to clean the appliance.

Safety Instructions (Continued)

DECLARATION OF CONFORMITY

The manufacturer declares that the cooktop is built using certified materials and requires the appliance to be installed in accordance with the standards currently in force. This appliance must be used by a trained person for domestic purposes only.

TO AVOID DAMAGING YOUR COOKTOP

- The ceramic glass can be damaged by objects falling onto it.
- The ceramic glass edge can be damaged by knocks from cookware.
- Cast iron and cast aluminium cookware with damaged bases may scratch the ceramic surface if they are dragged across it.
- Pans should be lifted on and off the cooktop surface and not dragged.
- Cooking zones should not be switched on without cookware placed on it. Also the cookware should not be empty.

UNPACKING

During transportation, protective packaging was used to protect the appliance against any damage. After unpacking, please dispose of all elements of packaging in a way that will not cause damage to the environment. All materials used for packaging the appliance are environmentally friendly; they are 100% recyclable and are marked with the appropriate symbol.

- During unpacking, the packaging materials (polythene bags, polystyrene pieces, etc.) should be kept out of reach of children.

DISPOSAL OF THE APPLIANCE

Old appliances should not simply be disposed of with normal household waste, but should be delivered to a collection and recycling centre for electric and electronic equipment. A symbol shown on the product, the instruction manual or the packaging shows that it is suitable for recycling.

Materials used inside the appliance are recyclable and are labelled with information concerning this. By recycling materials or other parts from used devices you are making a significant contribution to the protection of our environment.

Information on appropriate disposal centres for used devices can be provided by your local authority.

Your Esatto Cooktop

SPECIFICATIONS

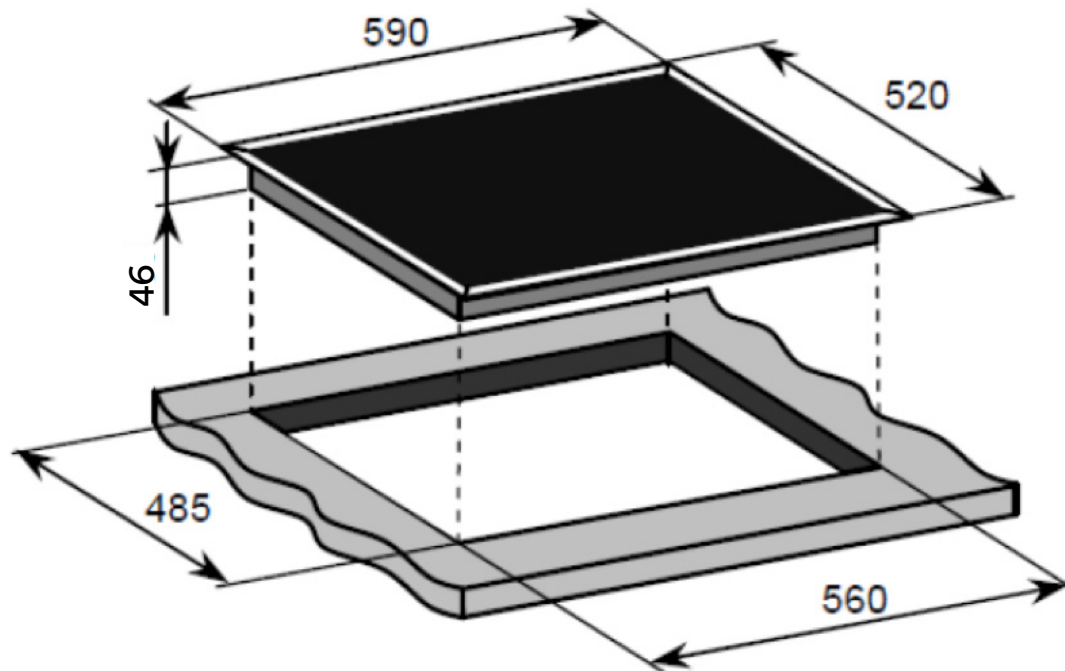

MODEL	PRODUCT DIMENSIONS (WxDxH)	CUT-OUT DIMENSIONS (WxD)
IE61K	590mm, 520mm, 50mm	560mm x 485mm
MODEL	BURNERS	OTHER
IE61K	2 x 1.80 kW radiant zones (Ø 180mm) 2 x 1.20 kW radiant zones (Ø 145mm)	Touch control operation 4 x Individual residual heat indicators Frameless design

CERAMIC COOKTOP SURFACE LAYOUT

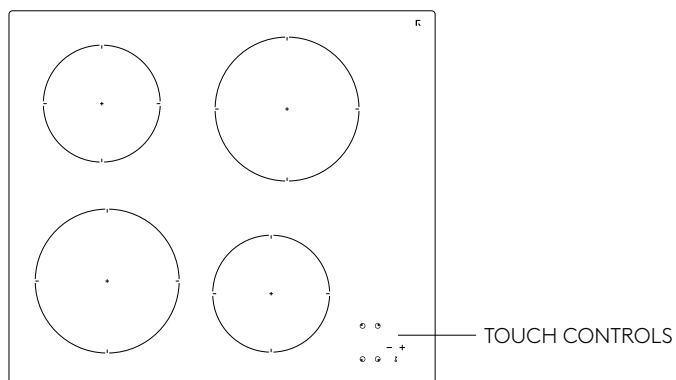

- 1 1.20 kW zone (Ø 145mm)
- 2 1.80 kW zone (Ø 180mm)
- 3 1.20 kW zone (Ø 145mm)
- 4 1.80 kW zone (Ø 180mm)

Your Esatto Cooktop (Continued)

It's important to carefully read the following installation instructions before beginning the installation of your cooktop.

Important! The connection of this cooktop must be carried out by a suitably qualified and licensed person, in accordance with the current version of the following:

- AS/NZS 3000: 2007 Wiring Regulations
- 2010 Electricity Safety Regulations
- The installation instructions within this user manual

POSITIONING

The adjacent cabinetry and wall materials must be able to withstand a minimum temperature rise of 85°C above the ambient temperature of the room.

- This cooktop has been designed for use within a kitchen. The cooktop must not be installed in a bathroom or shower room.

This appliance is classified as Class 3 and therefore is to be built into a kitchen unit (depending on size) or 600mm deep worktop, providing the following minimum distances are allowed:

- The edges of the hob must be a minimum distance of 55mm from a side or rear wall.
- 700mm between the highest point of the hob surface (including the burners) and the underside of any horizontal surface directly above it.
- 400mm between the hob surface, providing that the underside of the horizontal surface is in line with the outer edge of the hob. If the underside of the horizontal surface is lower than 400 mm, then it must be at least 50 mm away from the outer edges of the hob.
- 50mm clearance around the appliance and between the hob surface and any combustible materials.

INSTALLING THE COOKTOP

- Cut a hole in the bench top that corresponds with the relevant drawing shown below.

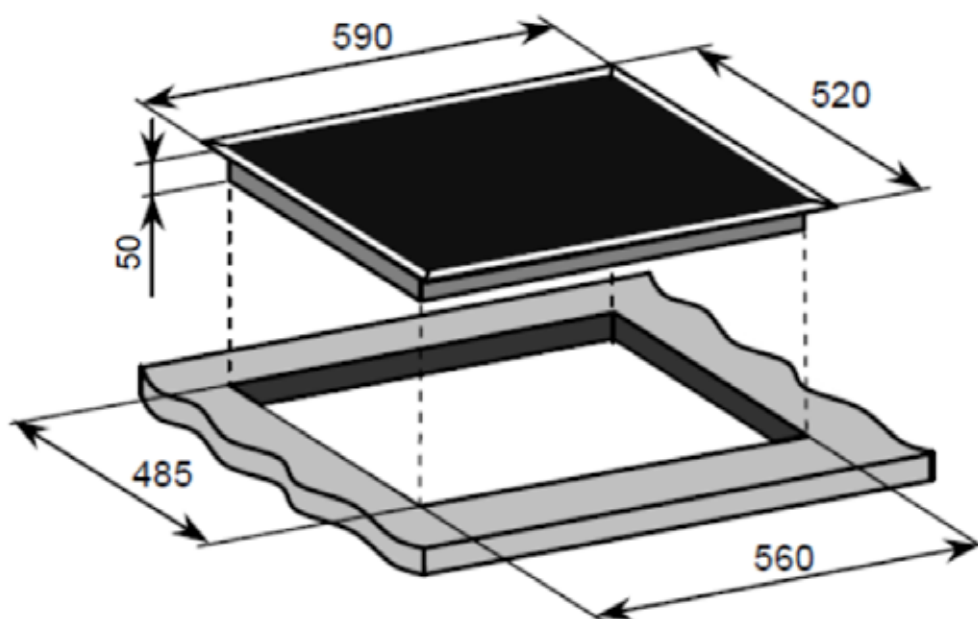

Installation Instructions

IMPORTANT!

You must observe the ventilation requirements shown in the drawing below.

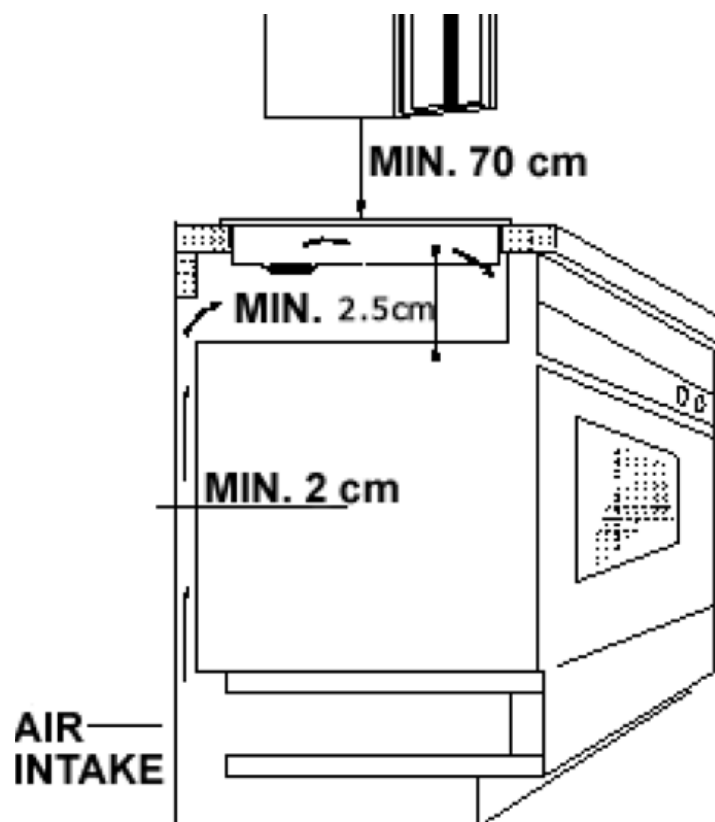

IMPORTANT!

There are ventilation holes around the outside of the cooktop. You must ensure that these holes are not blocked by the benchtop, when you put the cooktop into position.



Your Esatto cooktop comes fitted with the sealing strip already attached to the underside of the cooktop. This should not be removed as it will prevent liquid or spillages from penetrating the underside of the cooktop.

IMPORTANT!

Do not use a silicon sealant to seal the appliance against the aperture. This will make it difficult to remove the cooktop from the aperture in the future, particularly if it needs to be serviced.



Carefully lower the cooktop into the cut-out.

ELECTRICAL CONNECTION

IMPORTANT!

The connection of this cooktop must be carried out by a suitably qualified and licensed electrician, in accordance with the current versions of the following:

- Gas Safety and Measurement Regulations 2010
- AS/NZS 3000 Wiring Rules
- Electricity Safety Regulations 2010
- The installation instructions within this user manual

Before connecting the cooktop, make sure that the supply voltage marked on the rating plate corresponds with that of your mains supply voltage.

WARNING!

The cooktop must be earthed.

Installation Instructions (Continued)

- The appliance must be wired into a 30A double pole switched fused spur outlet, having 3mm contact separation and placed in an easily accessible position adjacent to the appliance. It should not be located above the appliance and no more that 1.25m away from it.
- The spur outlet must still be accessible even when your cooktop is located in its operating position.
- Cable type: H05 VVF 3 core x 4mm²

CONNECTING THE MAINS SUPPLY CABLE

- The mains terminal block is located on the underside of the cooktop and the terminals are accessible by removing the terminal block cover. This is done by depressing the front of the cover and releasing it from the securing clips.

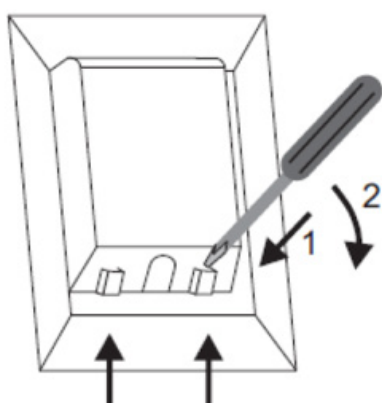

- The cable connections must be in accordance with the diagram located on the bottom of the cooktop (see below). The links must also be positioned as indicated.

<p style="text-align: center;">CONNECTION DIAGRAM</p> <p style="text-align: center;">Caution:</p> <p>Voltage of heating elements 220-240V~</p> <p>Caution! In the event of any connection the safety wire must be connected to the PE terminal</p>	
<p>For 220-240V~ , L need to be connected 1-2 terminals with one connection bridge, N need to be connected 4-5 terminals with one connection bridge . The safety wire must be connected to the PE terminal</p>	

- You should use a good quality screwdriver to carefully, fully tighten ALL of the terminal screws.
- If when the cooktop is first switched on, only two of the zones work, you should recheck that the terminal screws are all fully tightened and the links are in position. This should be done before contacting the Customer Care Department.

IMPORTANT!

- The cooktop must NOT be connected to the mains supply by means of a 10A or 15A plug and socket.
- The cable can be looped if necessary, but make sure that is not kinked or trapped when the cooktop is in position. Care must be taken to avoid the cable being in contact with hot parts of the appliance.

Installation Instructions (Continued)

REPLACING THE MAINS SUPPLY CABLE

If the mains supply cable is damaged, then it must be replaced by an appropriate replacement which can be obtained via the manufacturer or its service agents, in order to avoid hazard.

IMPORTANT!

The replacement of the mains supply cable must be carried out by a suitably qualified and licensed electrician.

The mains supply cable should be replaced in accordance with the following instructions:

- Switch the appliance off at the socket.
- Open the terminal block on the underside of the cooktop.
- Unscrew the terminal screws fixing the cable.
- Replace the cable with one of the same length and in accordance with the specification given on pages 17 - 18.
- The “green-yellow” earth wire must be connected to the terminal marked \perp . It must be about 10 mm longer than the live and neutral wires.
- The “blue” neutral wire must be connected to the terminal marked with letter (N) - the live wire must be connected to the terminal marked with letter (L).

Operating your Cooktop

BEFORE FIRST USE

IMPORTANT!

You should clean the ceramic cooktop surface (refer to the “Cleaning and Maintenance” section).



You should switch on one cooking zone at a time, for 5 minutes at the maximum setting. This will help to eliminate any new smell that exists and evaporate any humidity that has formed on the heating elements during transit.



Do not burn off more than one zone at once.



You must place a saucepan filled half full with cold water on each cooking zone as you burn it off.

TOUCH CONTROLS



All operations are performed by means of the touch controls that can be found on the lower right hand side of the cooktop (when standing in front).

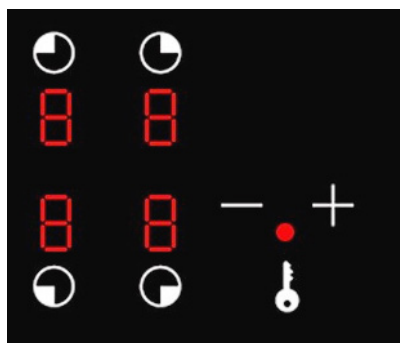

SWITCHING ON A COOKING ZONE AND SETTING A POWER LEVEL



After selecting your cooking zone by touching the zone indicator symbol (shown below), you then use the +/- buttons to increase or decrease your desired heating level (indicated by the LED display below).



IMPORTANT!

When you have finished using a zone, make sure that you set the zone to OFF. This is done by firstly pressing the relevant zone indicator icon once to select your zone and then pressing once again to switch off (i.e. Double press).

RESIDUAL HEAT INDICATORS



After a zone is switched off, the corresponding cooking zone will show an “H” in the control panel. This means that the temperature of the zone is over 50°C and is therefore still high enough to cause injury.



The residual heat indicator will go out after the temperature of the zone falls below 50°C.

IMPORTANT!

The residual heat indicator will disappear if the mains supply to the product is cut.

WARNING!

It is still possible to burn yourself on a cooktop zone, even when the residual heat indicator has gone off. Always use caution when using the cooktop.

Operating your Cooktop

CHILD LOCK

Your cooktop features a child lock safety feature. The cooktop can be locked to prevent settings being accidentally changed and when active, is indicated by the LED positioned above the lock symbol. When active, the only button that can be used is the safety lock itself. To activate or deactivate the child lock, press and hold the lock button for 3 seconds.

SAFETY CUT-OFF

Your cooktop features a safety cut-off which will activate after 1 hour of inactivity. When your cooktop is on but no buttons pressed or settings adjusted, the cooktop will automatically switch off.

COOKTOP GUIDELINES

- The first few times the cooktop is used, it may give off a burning smell. This smell will disappear completely with repeated use.
- The cooktop surface is fitted with cooking areas of different diameter and power.
- The positions where the heat will radiate from are clearly marked on the cooktop. The saucepans must be positioned exactly on these zones for efficient heating to occur. Pans should have the same diameter as the cooking zone that they are being used on.
- You should not use saucepans with rough bottoms, as this can scratch the ceramic surface.
- Before use, make sure that the bottoms of the saucepans are clean and dry.
- When cold, the bottom of the pans should be slightly concave, as they expand when hot and lie flat on the surface of the cooktop.
- This will allow the heat to transfer more easily.
- The best thickness for the bottom of the pans is 2–3 mm of enameled steel and 4–6 mm for stainless steel with sandwich type bottoms.
- If these rules are not followed, then there will be a great loss of heat and energy. Heat not absorbed by the saucepan, will spread to the cooktop, frame and surrounding cabinets.
- Preferably cover pans with a lid to permit cooking at a lower heat.
- Always cook vegetables and potatoes, etc. in as little water to reduce cooking times.
- Food or liquid that has high sugar content may damage the cooktop if it comes into contact with the ceramic cooktop surface. Any spillages should be wiped up immediately, however this may not prevent the cooktop surface from becoming damaged.

IMPORTANT!

The ceramic cooktop surface is tough; however it is not unbreakable and can be damaged especially if pointed or hard objects are allowed to fall on it with some force.

WARNING!

Do not use the cooktop if the surface becomes broken or cracked. You should contact the Residentia Group Support team immediately.

Cleaning & Maintenance

By ensuring proper cleaning and maintenance of your Esatto cooktop, you can ensure that it will have a long and fault free operation.

WARNING! Do not start cleaning the cooktop until it has completely cooled.

CLEANING YOUR CERAMIC COOKTOP

- Any residues that are left on the cooktop surface from cleaning agents will damage it. You should remove any residues with warm water mixed with a little washing up liquid.
- Abrasive cleaners or sharp objects will damage the cooktop surface; you should clean it using warm water mixed with a little washing up liquid.
- Although it is easier to clean some deposits whilst the cooktop surface is still warm, you should take care not to burn yourself if cleaning the cooktop surface when it is still warm.

After each use:

- Wipe the cooktop over with a damp cloth.
- Dry the cooktop by rubbing the surface with a clean cloth.

Type of deposit	Remove immediately?	Remove when the cooktop has cooled down?	What should I use to remove the deposit?
Sugar or food/liquid containing sugar	Yes	No	Ceramic cooktop scraper
Tin foil or plastic	Yes	No	Ceramic cooktop scraper
Fat splashes	No	Yes	Ceramic cooktop cleaner
Metallic discolouration	No	Yes	Ceramic cooktop cleaner
Water splashes or water rings	No	Yes	Ceramic cooktop cleaner

USING A SPECIALIST CERAMIC COOKTOP CLEANER

It is possible to purchase a specialist ceramic cooktop cleaner/conditioner.

You should follow the instructions given by the manufacturer of the cleaner and ensure that it is suitable for use on your appliance.

Troubleshooting

OPERATION IN CASE OF EMERGENCY

IMPORTANT! If your appliance appears to be operating incorrectly, then you should disconnect it from your mains gas and electrical supply and then contact the Residentia Group Support team on 1300 11 HELP (4357).

In the event of an emergency you should:

- Switch off all cooktop controls.
- Switch the cooktop off at the isolation switch or at the fusebox/switchboard.
- Call the Residentia Support Team on 1300 11 HELP (4357).

TROUBLESHOOTING

Some minor faults can be fixed by referring to the instructions given below. There is also a self-help section online at <http://www.residentiagroup.com.au>.

Q. The cooking zones are not functioning or will not switch on.

A. Check that the mains electrical supply to the appliance is correct and working. Check the mains fuse.

Q. The residual heat indicator has not come on after I have switched a cooking zone off.

A. The cooking zone has only been turned on for less than 30 seconds.

IMPORTANT! If the cooking zone does appear to be hotter than 50°C or has been activated for longer than 30 seconds, and the residual heat indicator has not come on, you should call the Customer Care Department.

Q. A humming sound is heard when a cooking zone is selected.

A. This is normal; the sound will disappear when the zone heats up.

Q. The cooking zones have become discoloured.

A. This may be caused by burnt on remnants of food. This will not affect the working of the appliance. However you should make sure that the cleaning instructions are being followed regularly.

Note: That if an engineer is asked to attend whilst the product is under warranty and finds that the problem is not the result of an appliance fault, then you may be liable for the cost of the call out charge.

The appliance must be accessible for the engineer to perform any necessary repair. If your appliance is installed in such a way that an engineer is concerned that damage will be caused to the appliance or your kitchen, then they will not complete a repair. This includes situations where appliances have been tiled in or sealed in with sealant.

Please refer to the conditions of that appear on the warranty card at the rear of this user manual.

Technical Data

ELECTRICAL DETAILS

Rated Voltage: 220 - 240 Volts, 50-60 Hz

Supply Connection: 30A

(double pole switch fuse outlet with 3mm contact gap)

Max Rated Inputs: 6.0kW

Mains Supply Lead: 3 core x 4mm² (not supplied)

Warranty

WARRANTY TERMS AND CONDITIONS COOKING APPLIANCES

→ This document sets out the terms and conditions of the product warranties for Residentia Group Appliances. It is an important document. Please keep it with your proof of purchase documents in a safe place for future reference should you require service for your Appliance.

1. In this warranty
 - (a) 'acceptable quality' as referred to in clause 10 of this warranty has the same meaning referred to in the ACL;
 - (b) 'ACL' means Trade Practices Amendment (Australian Consumer Law) Act (No.2) 2010;
 - (c) 'Appliance' means any Residentia Group product purchased by you accompanied by this document;
 - (d) 'ASR' means Residentia Group authorised service representative;
 - (e) 'Residentia Group' means Residentia Group Pty Ltd of 20 Yaltara Avenue, Bundoora Victoria 3083, ACN 600 546 656 in respect of Appliances purchased in Australia;
 - (f) 'major failure' as referred to in clause 10 of this warranty has the same meaning referred to in the ACL and includes a situation when an Appliance cannot be repaired or it is uneconomic for Residentia Group, at its discretion, to repair an Appliance during the Warranty Period;
 - (g) 'Warranty Period' means:
 - (i) where the Appliance is used for personal, domestic or household use (i.e. normal single family use) as set out in the instruction manual, the Appliance is warranted against manufacturing defects in Australia for 24 months following the date of original purchase of the Appliance;
 - (h) 'you' means the purchaser of the Appliance not having purchased the Appliance for re-sale, and 'your' has a corresponding meaning.
2. This warranty only applies to Appliances purchased and used in Australia and is in addition to (and does not exclude, restrict, or modify in any way) any non-excludable statutory warranties in Australia.
3. During the Warranty Period Residentia Group or its ASR will, at no extra charge if your Appliance is readily accessible for service, without special equipment and subject to these terms and conditions, repair or replace any parts which it considers to be defective. Residentia Group or its ASR may use remanufactured parts to repair your Appliance. You agree that any replaced Appliances or parts become the property of Residentia Group. This warranty does not apply to light globes, batteries, filters or similar perishable parts.
4. Parts and Appliances not supplied by Residentia Group are not covered by this warranty.
5. You will bear the cost of transportation, travel and delivery of the Appliance to and from Residentia Group or its ASR. If you reside outside of the service area, you will bear the cost of:
 - (a) travel of an authorised representative;
 - (b) transportation and delivery of the Appliance to and from Residentia Group or its ASR, in all instances, unless the Appliance is transported by Residentia Group or its ASR, the Appliance is transported at the owner's cost and risk while in transit to and from Residentia Group or its ASR.
6. Proof of purchase is required before you can make a claim under this warranty.

Warranty continued

7. You may not make a claim under this warranty unless the defect claimed is due to faulty or defective parts or workmanship. Residentia Group is not liable in the following situations (which are not exhaustive):
- (a) the Appliance is damaged by:
 - (i) accident
 - (ii) misuse or abuse, including failure to properly maintain or service
 - (iii) normal wear and tear
 - (iv) power surges, electrical storm damage or incorrect power supply
 - (v) incomplete or improper installation
 - (vi) incorrect, improper or inappropriate operation
 - (vii) insect or vermin infestation
 - (viii) failure to comply with any additional instructions supplied with the Appliance;
 - (b) the Appliance is modified without authority from Residentia Group in writing;
 - (c) the Appliance's serial number or warranty seal has been removed or defaced;
 - (d) the Appliance was serviced or repaired by anyone other than Residentia Group, an authorised repairer or ASR.
8. This warranty, the contract to which it relates and the relationship between you and Residentia Group are governed by the law applicable where the Appliance was purchased.
9. To the extent permitted by law, Residentia Group excludes all warranties and liabilities (other than as contained in this document) including liability for any loss or damage whether direct or indirect arising from your purchase, use or non use of the Appliance.
10. For Appliances and services provided by Residentia Group in Australia, the Appliances come with a guarantee by Residentia Group that cannot be excluded under the Australian Consumer Law. You are entitled to a replacement or refund for a major failure and for compensation for any other reasonably foreseeable loss or damage. You are also entitled to have the Appliance repaired or replaced if the Appliance fails to be of acceptable quality and the failure does not amount to a major failure. The benefits to you given by this warranty are in addition to your other rights and remedies under a law in relation to the Appliances or services to which the warranty relates.
11. At all times during the Warranty Period, Residentia Group shall, at its discretion, determine whether repair, replacement or refund will apply if an Appliance has a valid warranty claim applicable to it.
12. To enquire about claiming under this warranty, please follow these steps:
- (a) carefully check the operating instructions, user manual and the terms of this warranty;
 - (b) have the model and serial number of the Appliance available;
 - (c) have the proof of purchase (e.g. an invoice) available;
 - (d) telephone the numbers shown below.
13. You accept that if you make a warranty claim, Residentia Group and its ASR may exchange information in relation to you to enable Residentia Group to meet its obligations under this warranty.

IMPORTANT Before calling for service, please ensure that the steps in point 12 have been followed.

Service: Please call 1300 11 HELP (4357)

Spare Parts: Please call 1300 11 SPARE (7727)

Model Code/s:

EE62T



E2447

Residentia